

S4F Zone, USC

Rack S4F01

Layout updated 07 Aug 07

Not for crate and rack installation

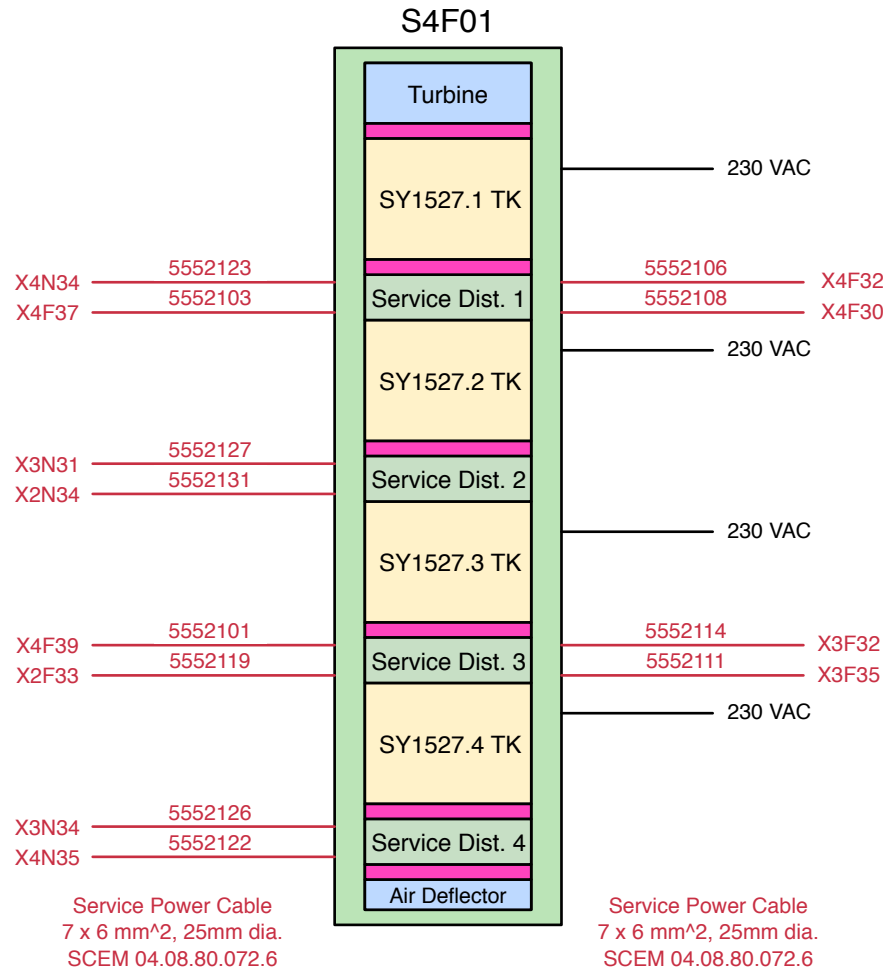

Power & Service Power Cabling

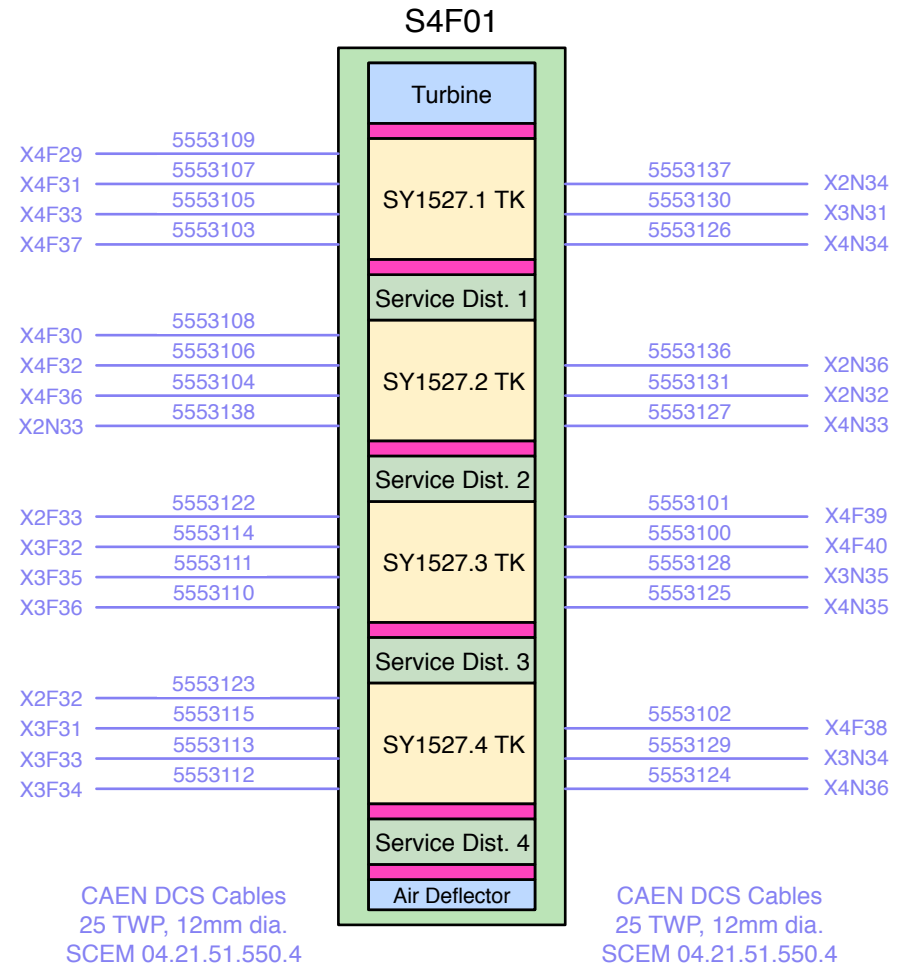

DCS Cabling

S4F Zone, USC

Rack S4F02

Layout updated 21 Nov 07

Not for crate and rack installation

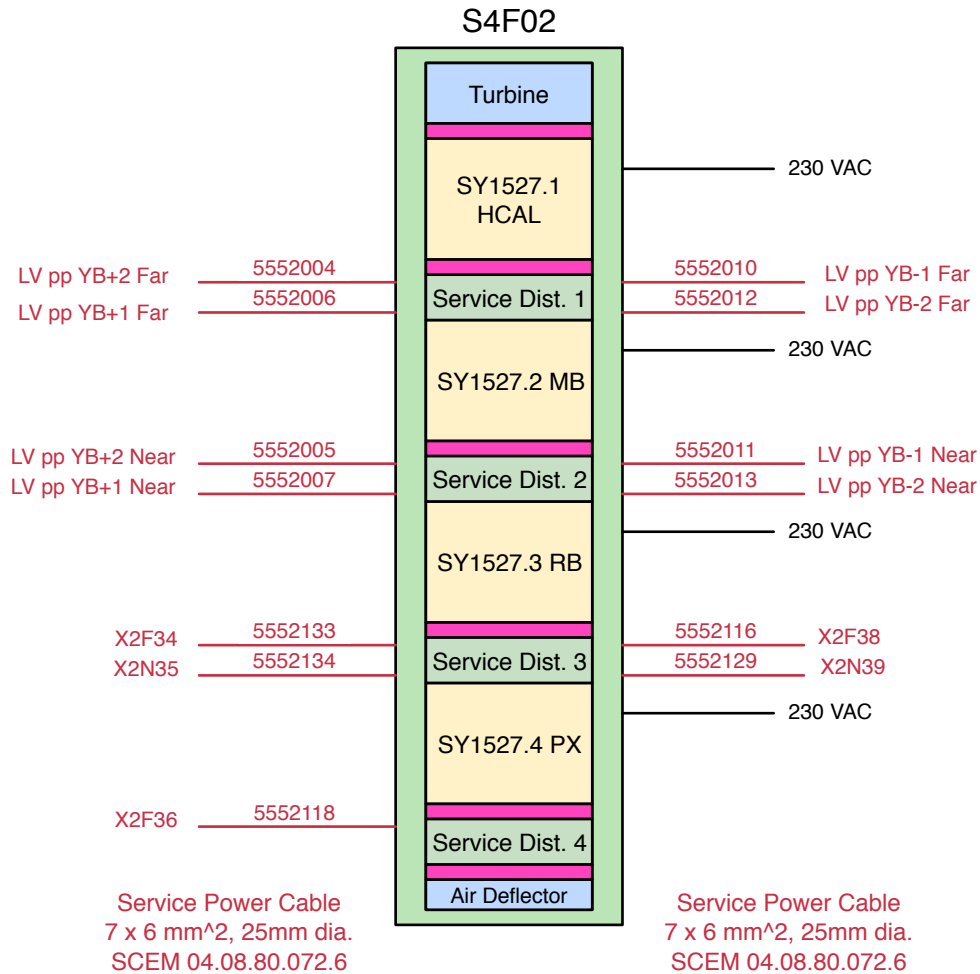

Power & Service Power Cabling

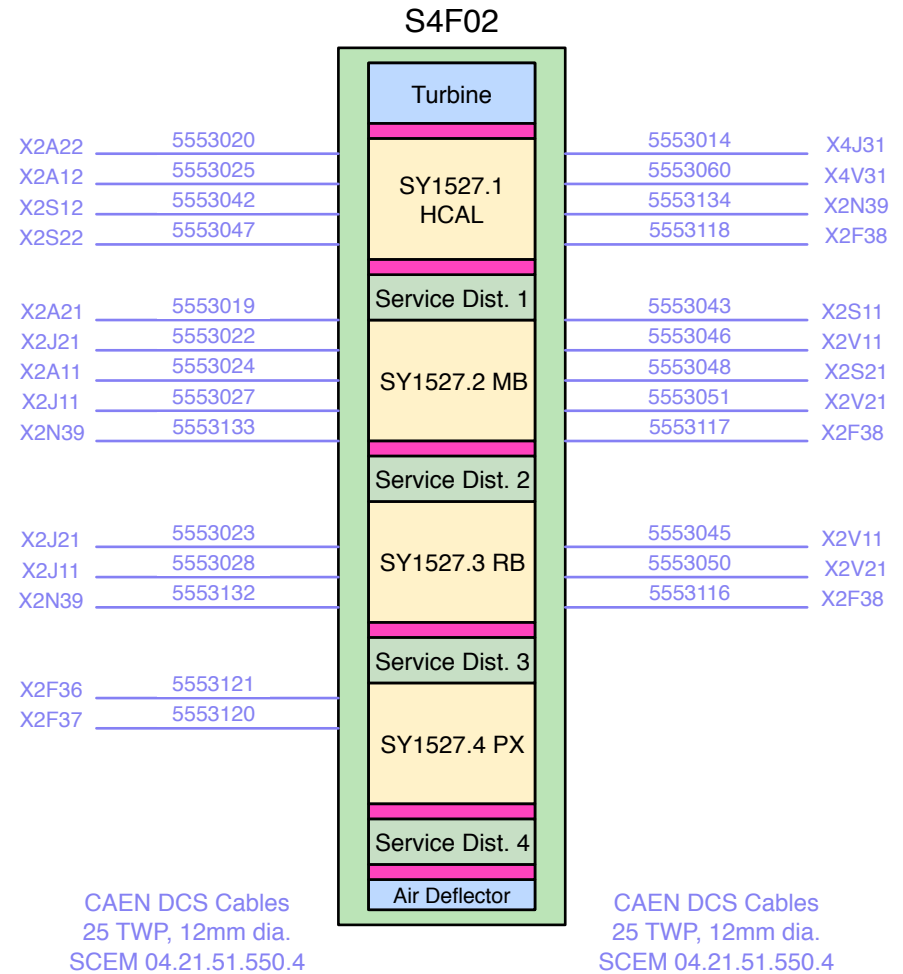

DCS Cabling

S4F Zone, USC

Rack S4F03

Layout updated 21 Nov 07

Not for crate and rack installation

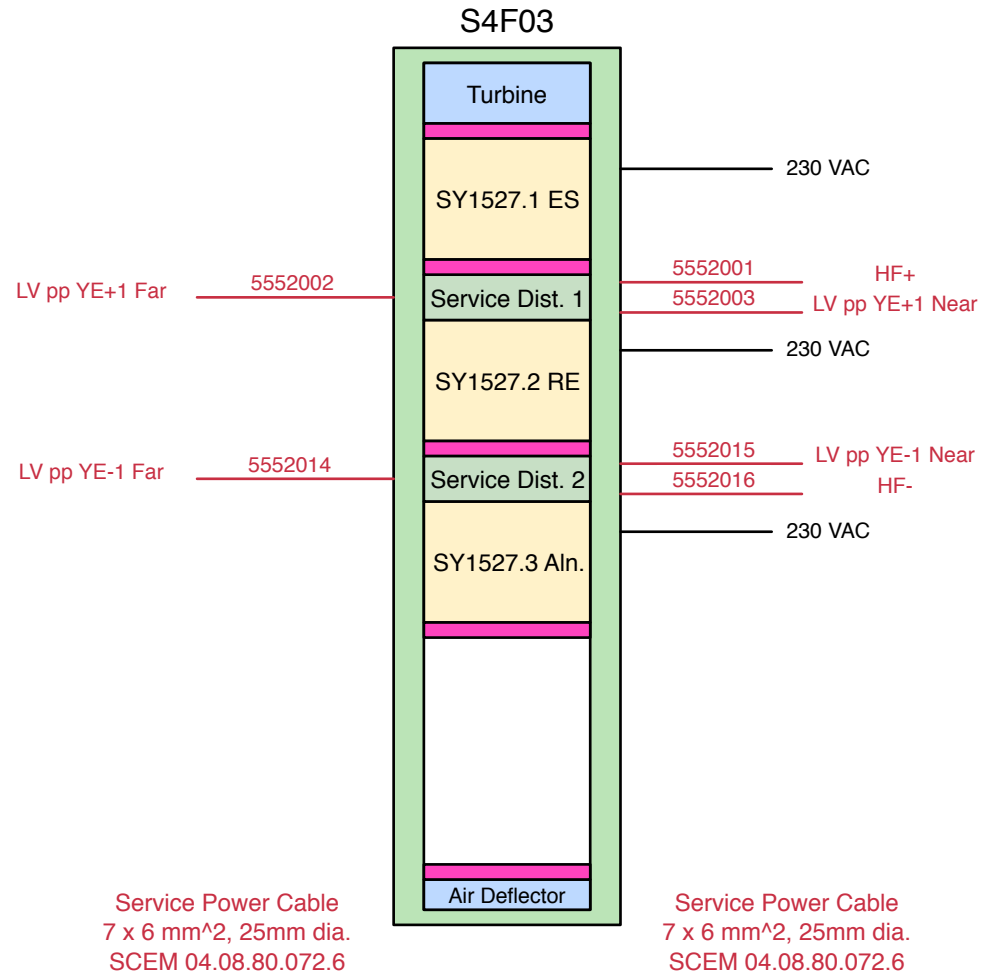

Power & Service Power Cabling

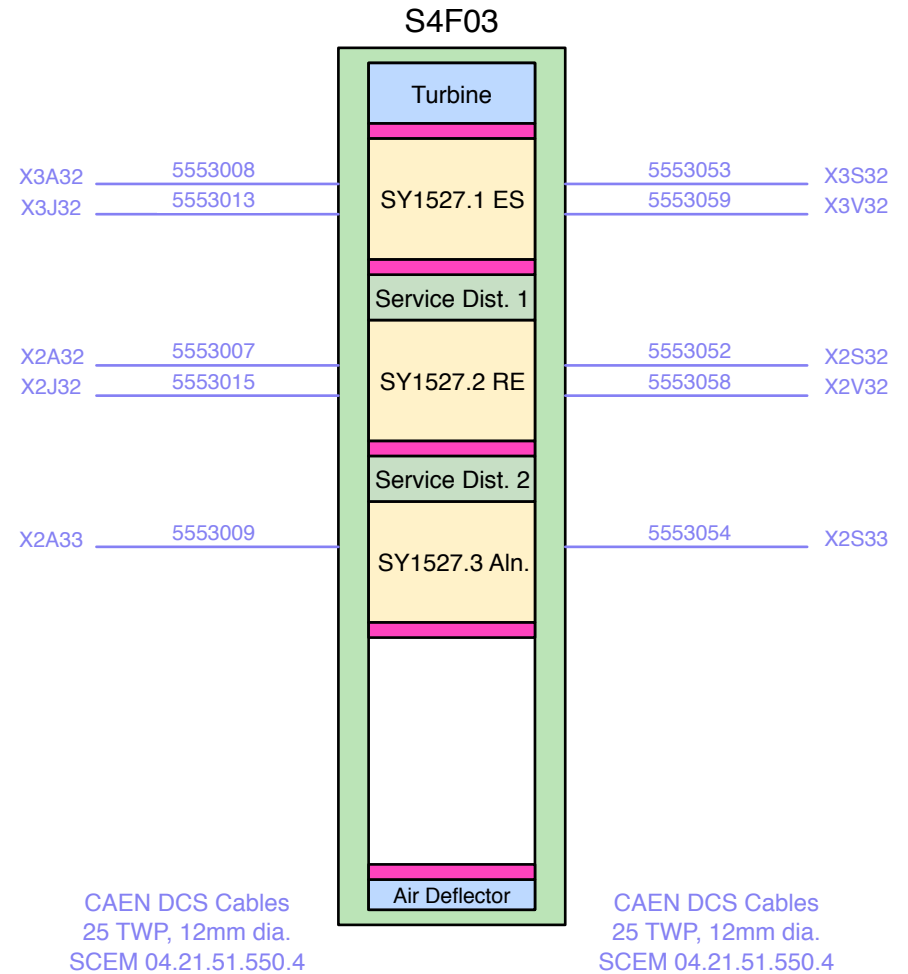

DCS Cabling

S4F Zone, USC

Rack S4F04

Layout updated 08 Nov 07

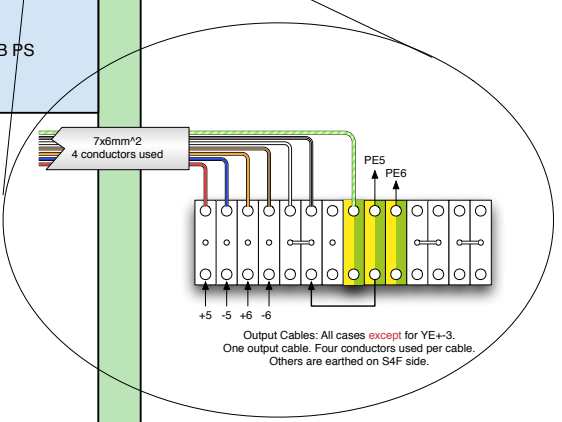
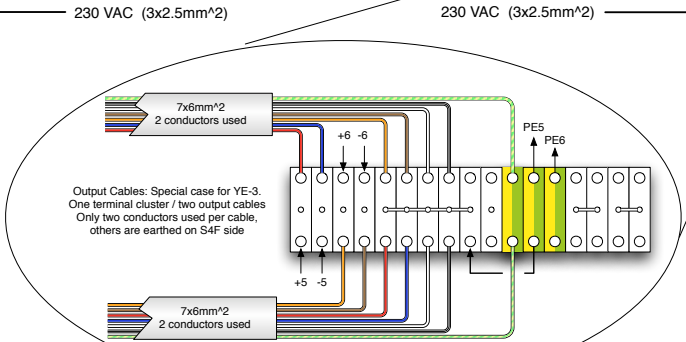
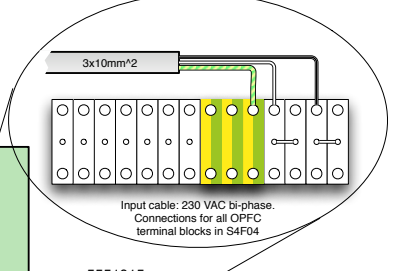
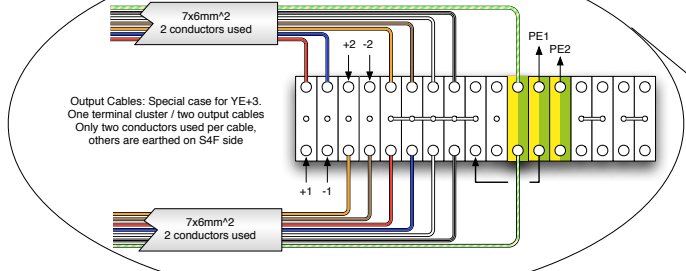
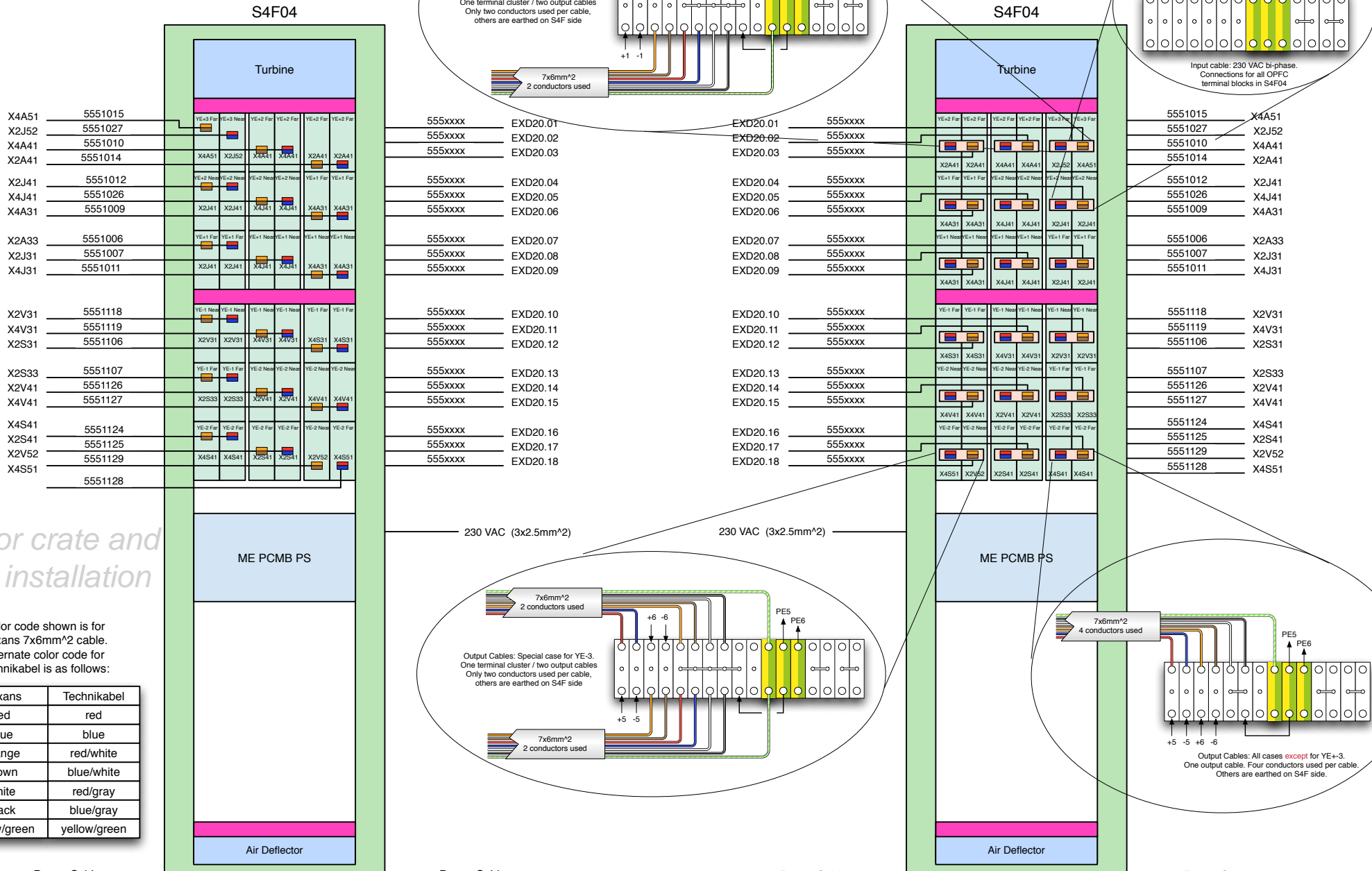

Not for crate and rack installation

Color code shown is for Nexans 7x6mm² cable. Alternate color code for Technikabel is as follows:

Nexans	Technikabel
red	red
blue	blue
orange	red/white
brown	blue/white
white	red/gray
black	blue/gray
yellow/green	yellow/green

Power Cables
7 x 6 mm², 25mm dia.
SCEM 04.08.80.072.6

Power Cables
3 x 10 mm², xx mm dia.
SCEM xxx

Power Cables
3 x 10 mm², xx mm dia.
SCEM xxx

Power Cables
7 x 6 mm², 25mm dia.
SCEM 04.08.80.072.6

Front View

Rear View

S4F Zone, USC

Rack S4F05

Layout updated 31 Aug 07

Not for crate and
rack installation

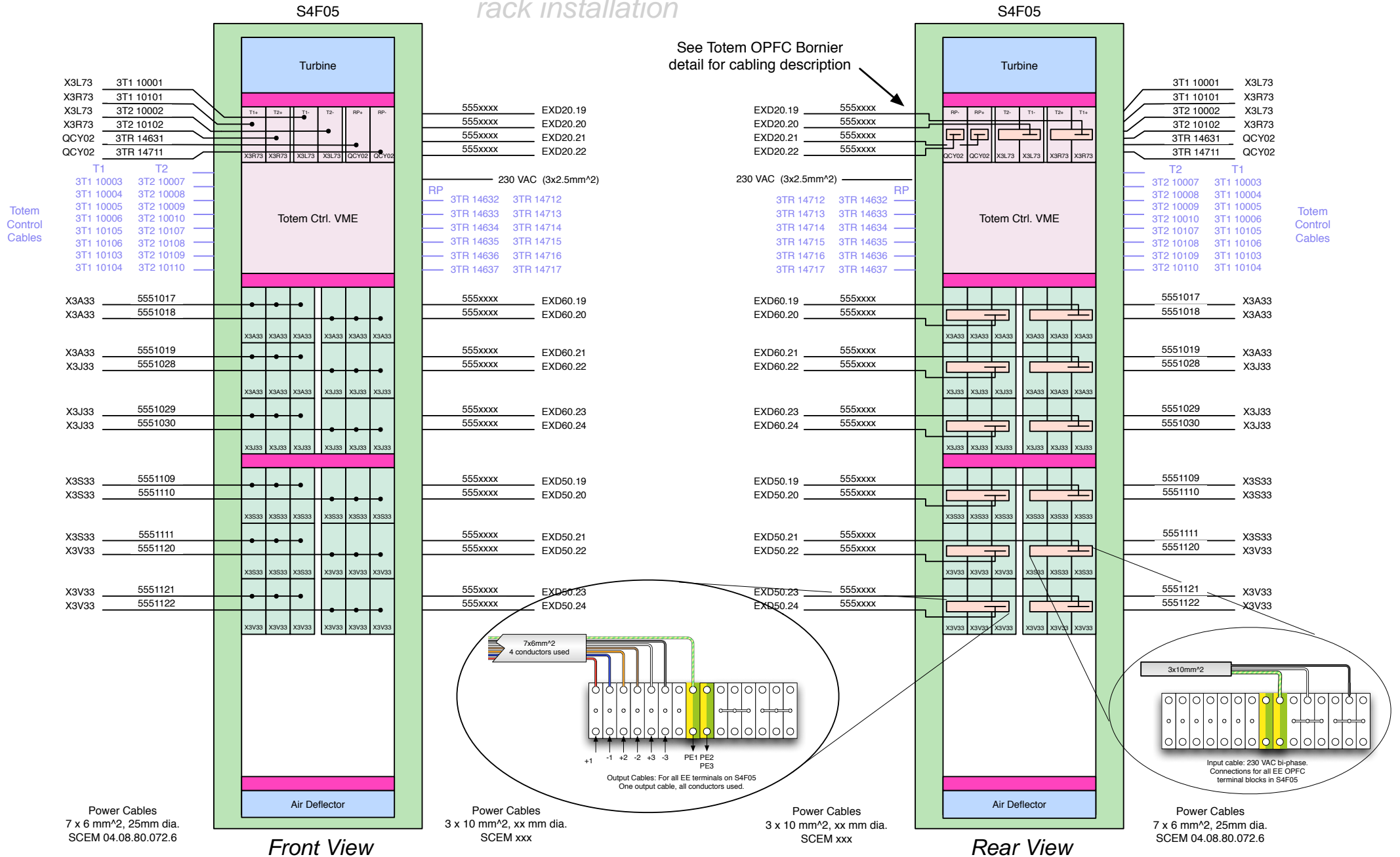

S4F Zone, USC

Rack S4F06

Layout updated 21 Oct 07

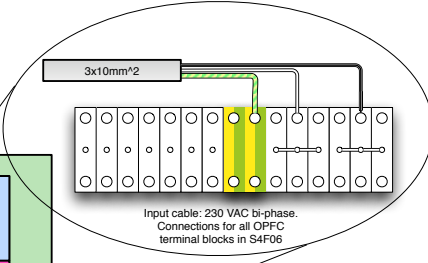
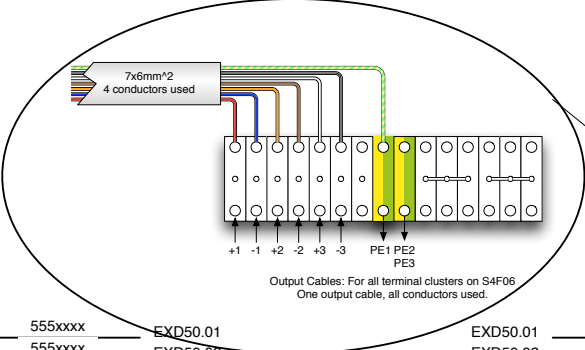
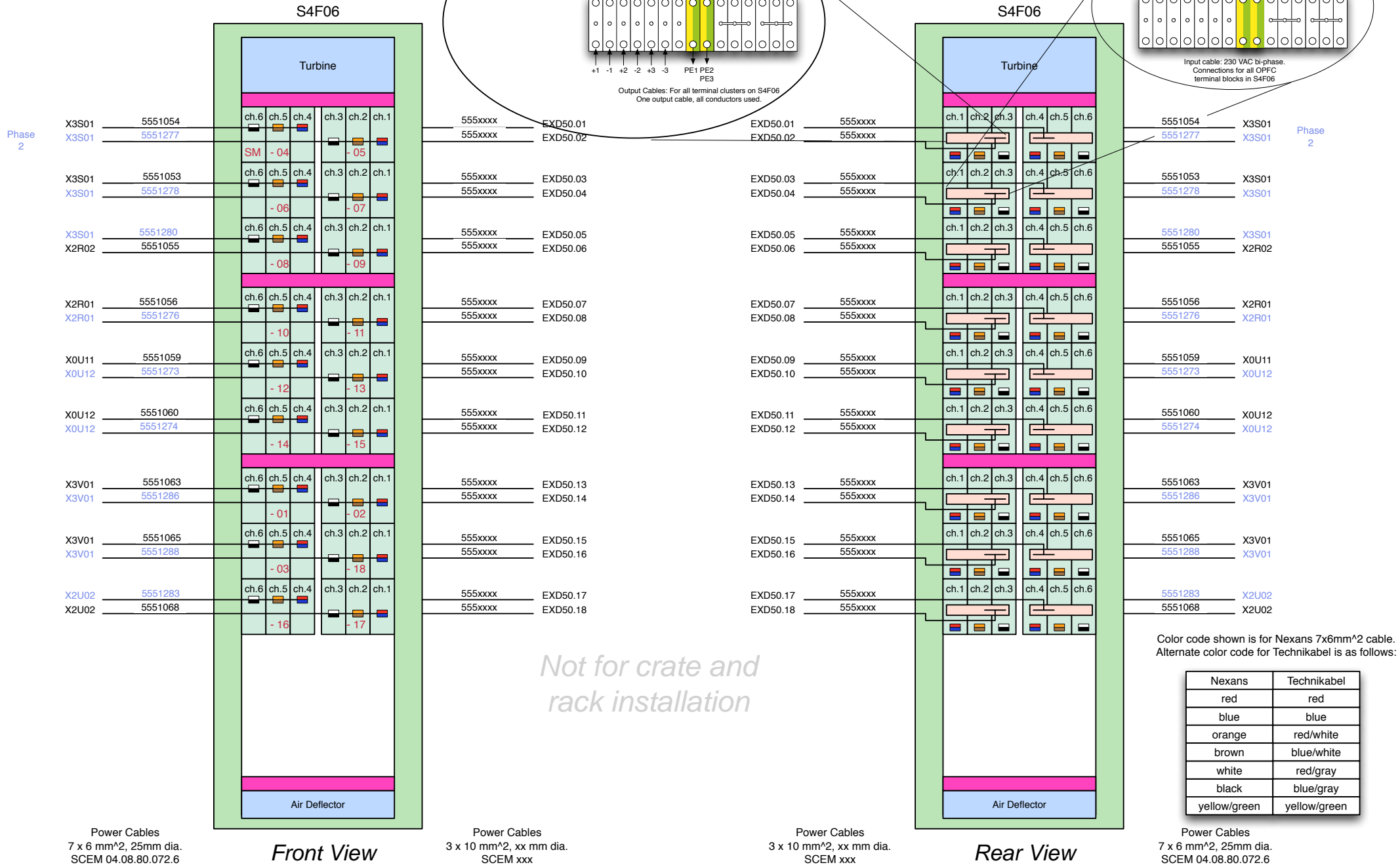

Phase 2

Phase 2

Terminal	Channel	Terminal	Channel
X3S01 5551054	ch.6 ch.5 ch.4 ch.3 ch.2 ch.1	EXD50.01 555xxxx	ch.1 ch.2 ch.3 ch.4 ch.5 ch.6
X3S01 5551277	SM -04 -05	EXD50.02 555xxxx	ch.1 ch.2 ch.3 ch.4 ch.5 ch.6
X3S01 5551053	ch.6 ch.5 ch.4 ch.3 ch.2 ch.1	EXD50.03 555xxxx	ch.1 ch.2 ch.3 ch.4 ch.5 ch.6
X3S01 5551278	-06 -07	EXD50.04 555xxxx	ch.1 ch.2 ch.3 ch.4 ch.5 ch.6
X3S01 5551280	ch.6 ch.5 ch.4 ch.3 ch.2 ch.1	EXD50.05 555xxxx	ch.1 ch.2 ch.3 ch.4 ch.5 ch.6
X2R02 5551055	-08 -09	EXD50.06 555xxxx	ch.1 ch.2 ch.3 ch.4 ch.5 ch.6
X2R01 5551056	ch.6 ch.5 ch.4 ch.3 ch.2 ch.1	EXD50.07 555xxxx	ch.1 ch.2 ch.3 ch.4 ch.5 ch.6
X2R01 5551276	-10 -11	EXD50.08 555xxxx	ch.1 ch.2 ch.3 ch.4 ch.5 ch.6
X0U11 5551059	ch.6 ch.5 ch.4 ch.3 ch.2 ch.1	EXD50.09 555xxxx	ch.1 ch.2 ch.3 ch.4 ch.5 ch.6
X0U12 5551273	-12 -13	EXD50.10 555xxxx	ch.1 ch.2 ch.3 ch.4 ch.5 ch.6
X0U12 5551060	ch.6 ch.5 ch.4 ch.3 ch.2 ch.1	EXD50.11 555xxxx	ch.1 ch.2 ch.3 ch.4 ch.5 ch.6
X0U12 5551274	-14 -15	EXD50.12 555xxxx	ch.1 ch.2 ch.3 ch.4 ch.5 ch.6
X3V01 5551063	ch.6 ch.5 ch.4 ch.3 ch.2 ch.1	EXD50.13 555xxxx	ch.1 ch.2 ch.3 ch.4 ch.5 ch.6
X3V01 5551286	-01 -02	EXD50.14 555xxxx	ch.1 ch.2 ch.3 ch.4 ch.5 ch.6
X3V01 5551065	ch.6 ch.5 ch.4 ch.3 ch.2 ch.1	EXD50.15 555xxxx	ch.1 ch.2 ch.3 ch.4 ch.5 ch.6
X3V01 5551288	-03 -18	EXD50.16 555xxxx	ch.1 ch.2 ch.3 ch.4 ch.5 ch.6
X2U02 5551283	ch.6 ch.5 ch.4 ch.3 ch.2 ch.1	EXD50.17 555xxxx	ch.1 ch.2 ch.3 ch.4 ch.5 ch.6
X2U02 5551068	-16 -17	EXD50.18 555xxxx	ch.1 ch.2 ch.3 ch.4 ch.5 ch.6

Power Cables
7 x 6 mm², 25mm dia.
SCEM 04.08.80.072.6

Power Cables
3 x 10 mm², xx mm dia.
SCEM xxx

Power Cables
3 x 10 mm², xx mm dia.
SCEM xxx

Power Cables
7 x 6 mm², 25mm dia.
SCEM 04.08.80.072.6

Nexans	Technikabel
red	red
blue	blue
orange	red/white
brown	blue/white
white	red/gray
black	blue/gray
yellow/green	yellow/green

S4F Zone, USC Rack S4F07

Layout updated 21 Oct 07

